

Fox baby

Daniel Chang

www.keepfoldingon.wordpress.com

Level: Intermediate

Steps: 27

Diagrammed by Marc Sky
(c) 2011

1

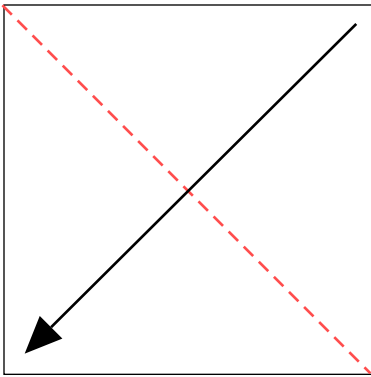

Fold in half, diagonally.

2

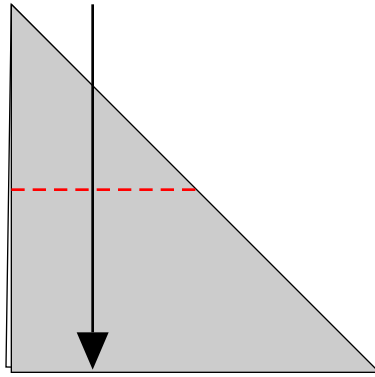

Fold down in half.

3

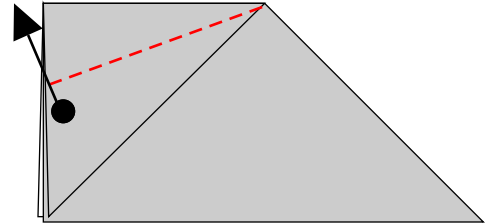

Fold angle bisector.

4

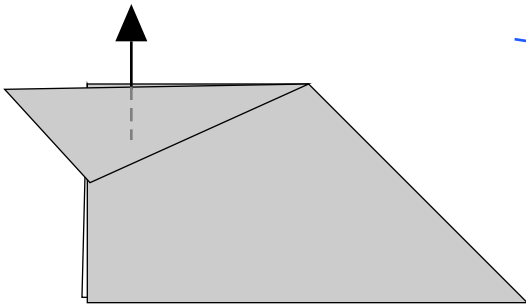

Pull up/open.

5

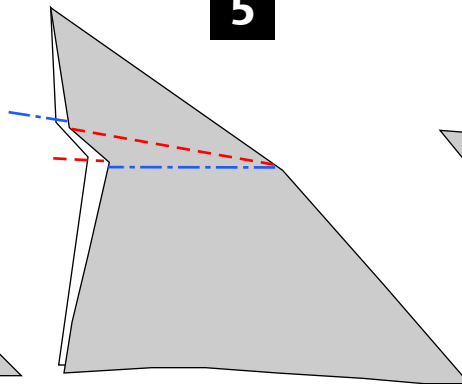

Inside crimp. Note: to make crimp easier, crease paper in both directions first.

6

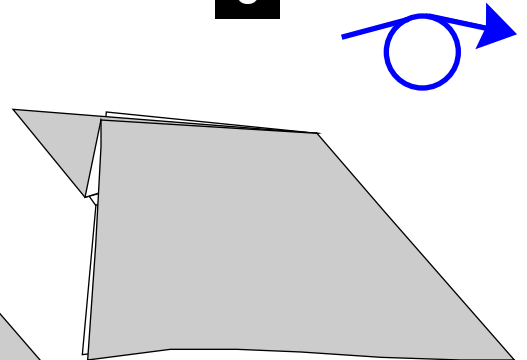

Flatten creases, then turn over.

7

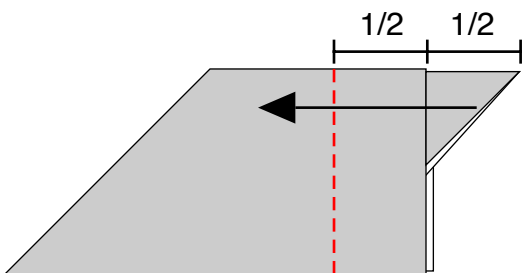

Crease to the left.

8

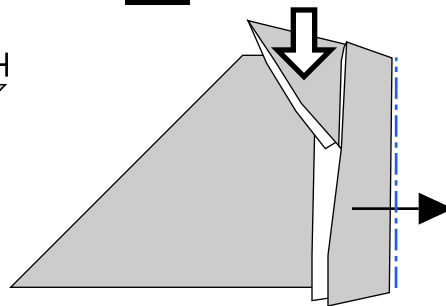

Pull open and squash down top.

9

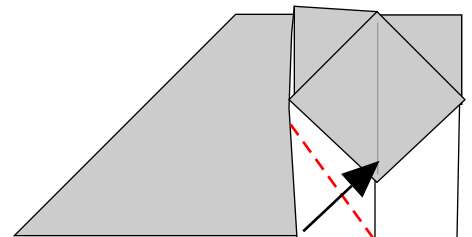

Fold up (overlapping the head).

10

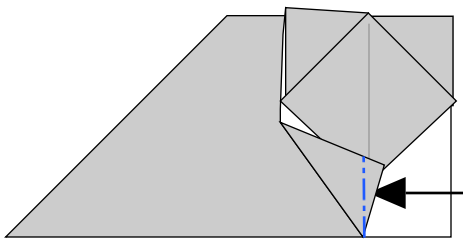

Fold behind, then tuck layer under head.

11

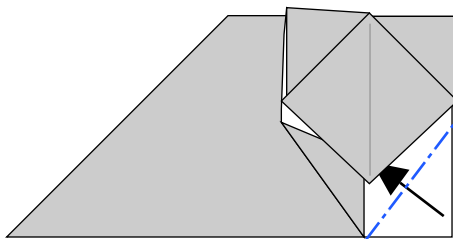

Fold, tuck under head and under left layer.

12

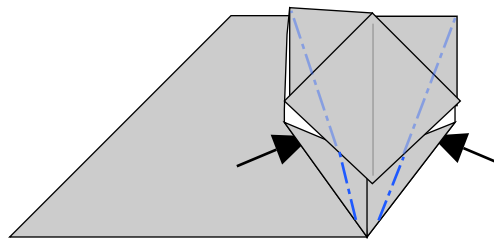

Fold underneath.

13

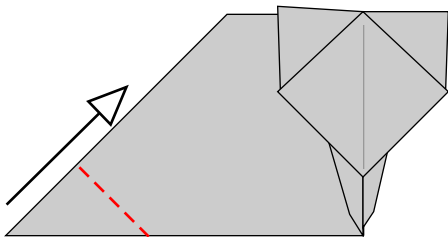

Outside reverse fold.

14

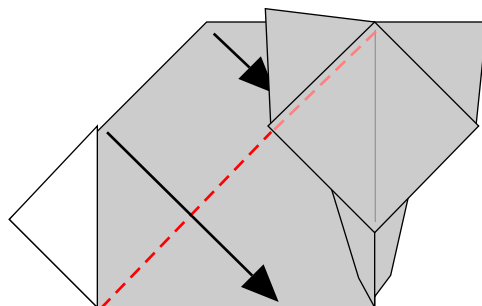

Fold diagonally down, underneath the head and leg.

15

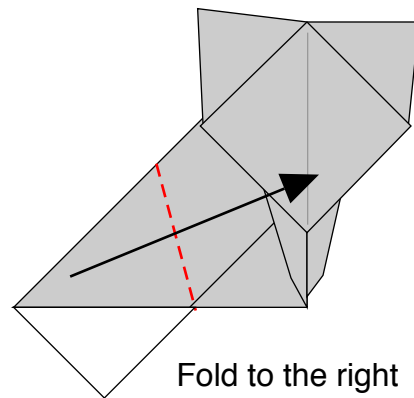

Fold to the right (overlapping head).

16

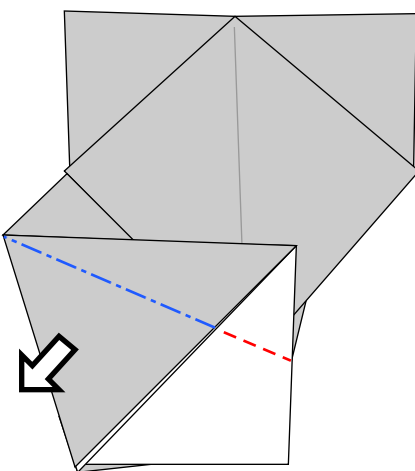

Squash fold.

17

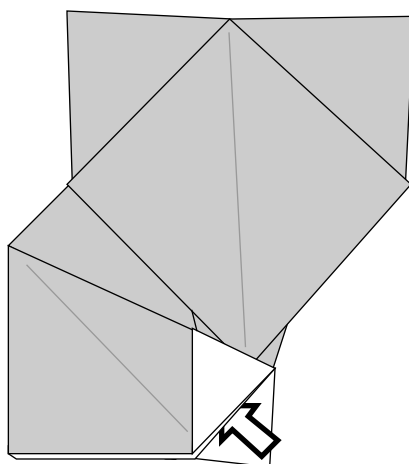

Open up.

18

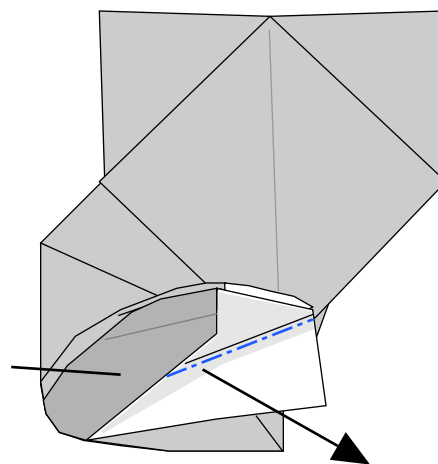

INSIDE VIEW

Pull out inner white layer flap, mountain folding/flattening it along its inside crease line.

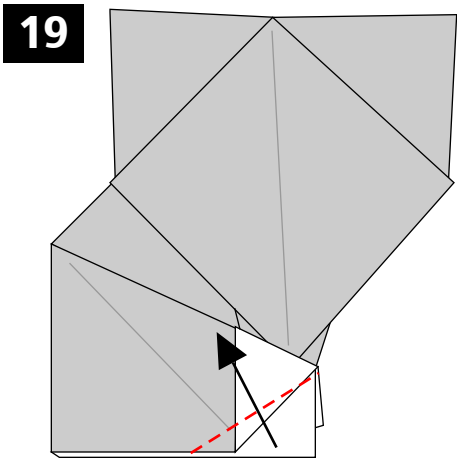

19

Fold flap upward.

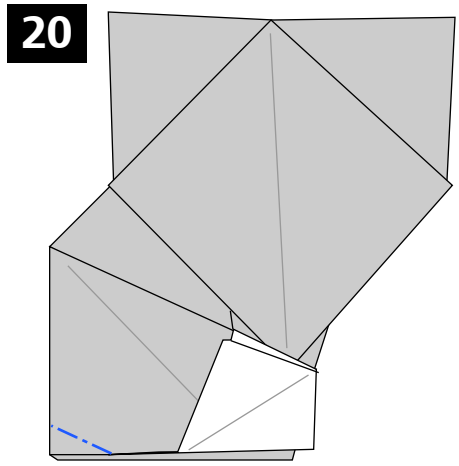

20

Inside reverse corner.
(See Notes)

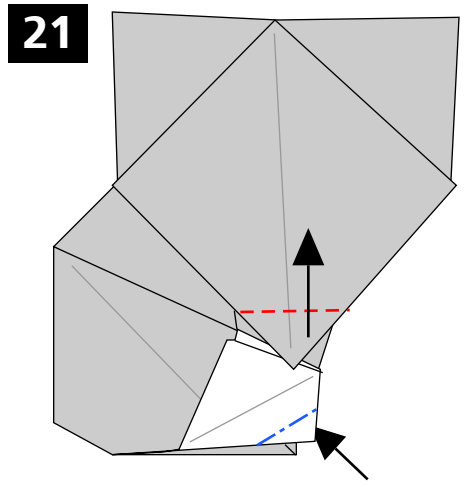

21

Fold bottom of head up.
Fold bottom tip of tail back.

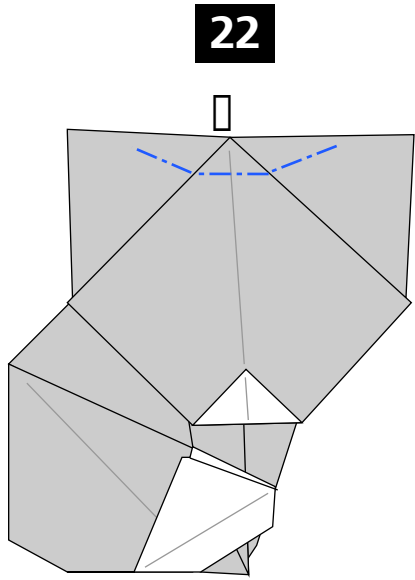

22

Crease down top of head/ears.

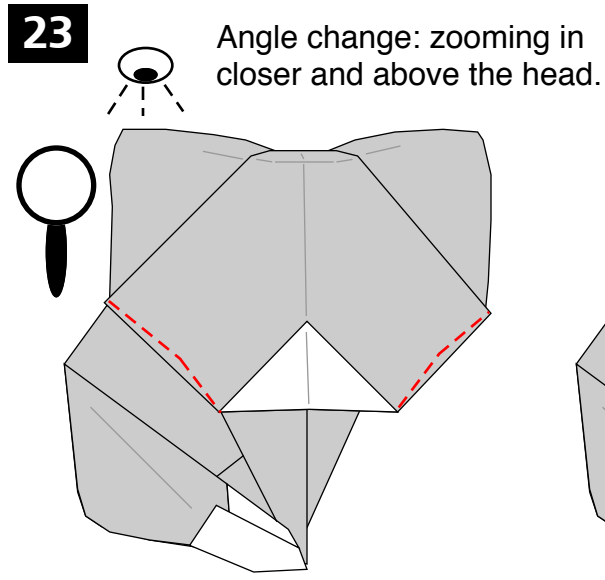

23

Angle change: zooming in
closer and above the head.

Fold/push in.

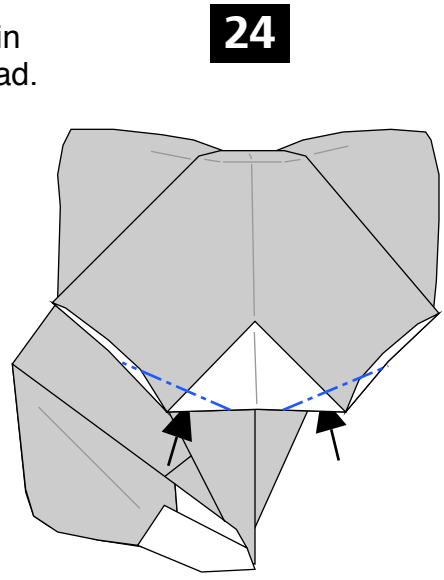

24

Fold under.

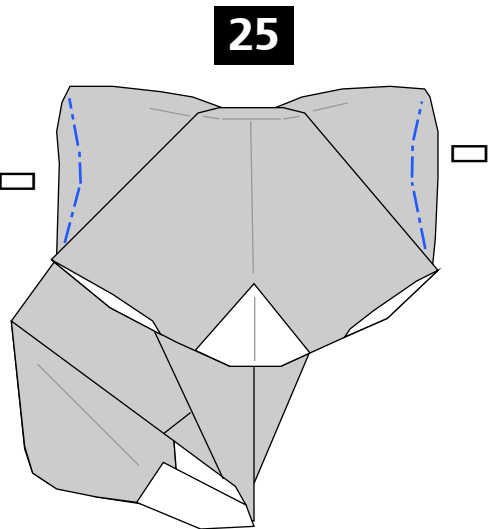

25

Push in and shape ears.

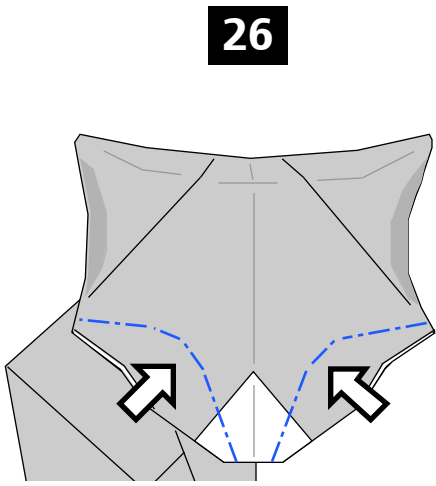

26

Push in and shape.

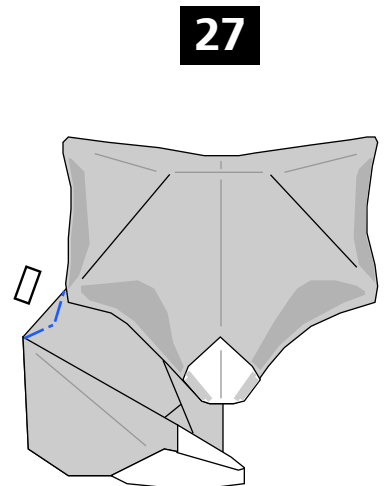

27

Push in to curve.

Notes

20

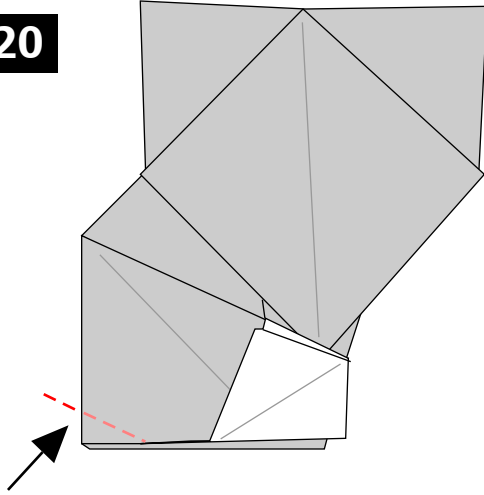

Alternatively, you can valley-fold only the inside layer on the corner of the tail/body inside to curve and lock the tail a bit more to the body.

